

# **Team TurkeyBurkey**

CanSat 2023 Pre Launch Report  
*Vancouver, Canada*

*Tyler Chen, Ryan Cheng, Mathew Fu, Eric Li, Bowen Yuan*



# Table of Contents

<b>1</b>	<b>INTRODUCTION</b>	<b>5</b>
1.1	Team Members	5
1.2	Mission objectives	5
<b>2</b>	<b>CANSAT DESCRIPTION</b>	<b>6</b>
2.1	Mission overview	6
2.2	Mechanical/structural design	7
2.3	Electrical design	8
2.4	Software design	9
2.5	Recovery system	10
<b>3</b>	<b>PROJECT PLANNING</b>	<b>11</b>
3.1	Time schedule of the CanSat preparation	11
3.2	Resource estimation	11
3.2.1	Budget	11
3.2.2	External support	11
3.3	Test plan	11
<b>4</b>	<b>OUTREACH PROGRAMME</b>	<b>12</b>
<b>5</b>	<b>SPECIFICATIONS</b>	<b>13</b>



# 1 INTRODUCTION

## 1.1 Team Members

**Tyler Chen**



**Ryan Cheng**

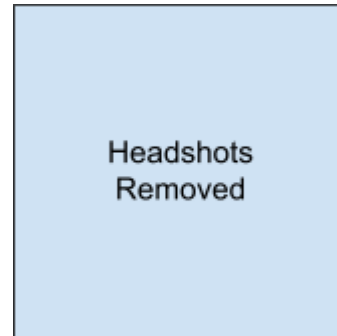

**Mathew Fu**



**Eric Li**

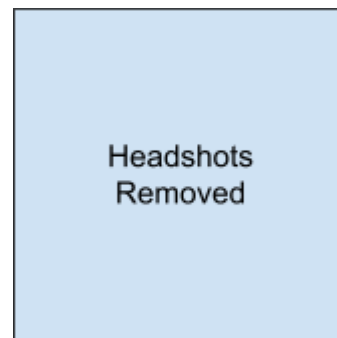

**Bowen Yuan**



**Mark Lam [Supervisor]**

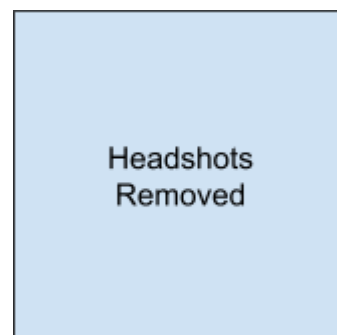



## 1.2 Mission objectives

Seismometers are both useful and precise when it comes to measuring earthquakes or tremors. In humanity's ongoing efforts in interplanetary exploration, scientists have developed an abundance of methods to assess the inhabitability of celestial bodies. However, to our understanding, there is yet to be any way to remotely test seismic activities—one must conduct these tests on the surface of these planetary bodies.

Our home city of Vancouver is situated within the *ring of fire*, a region surrounding the Pacific Ocean particularly prone to seismic activity, and members of our group are far from strangers to earthquake threats and drills. Our experiences paired with inspiration from NASA's Mars INSIGHT mission, which measured Mars-quakes and data about its seismic activity, led us to decide on a mission to measure the tremors from seismic activity in the terrain surrounding the landing site of the CanSat and create a seismograph.

For our secondary mission, we hope to convert the seismograph measurements to the Richter scale and determine the magnitude of the tremors. Altogether, we hope our CanSat will accomplish the following:

- Make a CanSat that can maintain structural and functional integrity while under the forces of launch/freefall.
- Collect air temperature and pressure data during freefall.
- Measure and record vibrations and tremors upon landing.
- Maintain a stable radio connection during freefall and landing over which experimental data may be transmitted.
- Receive accurate and precise data.



## 2 CANSAT DESCRIPTION

### 2.1 Mission overview

*Overall mission: design and create a CanSat to be launched and deployed by a rocket at an altitude approximately equal to 1000m. The CanSat is to descend no faster than 11 meters/second and take measurements of air pressure and temperature. Once landed, the CanSat is to measure seismic activity at the site of landing for an hour at a rate of 115200 baud.*

The onboard Arduino gyro converts physical movements from seismic activity into electrical signals through the analog inputs of the arduino. The entire process of parsing this data has already been studied extensively by the Japanese Meteorological Agency (JMA) and has been further developed to meet the needs of our CanSat. Our process is as follows:

1. Get the X, Y, and Z angles and calculate the X-, Y-, and Z-components of measured acceleration
2. Take multiple measurements in a short span of time (in our case 12 measurements every 0.12 seconds)
3. Apply a Fourier transform to the 12-item datasets for the two horizontal (X and Y) and single vertical (Z) acceleration components, separating each acceleration into multiple trigonometric functions
4. Multiply these trigonometric functions by constants calculated by the JMA to "smooth" out the data, reducing instrumental noise
5. Perform the inverse Fourier transform that was applied in step 3 to merge the trigonometric functions back into the respective X-, Y-, and Z-components
6. Synthesize these three components into a single vector
7. Calculate the seismic intensity of this calculated vector and its corresponding value on the Richter Scale. The formula we derived that creates the best data given our instrumentation follows the format:

$$\text{Intensity} = 2 \log a + 0.94$$

Where a is the magnitude of the derived single vector.



The CanSat will carry the following components:

- Arduino Nano - responsible for controlling all of the modules and parsing and transmitting their data.
- MPU6050 gyroscope module - used as a seismometer.
- REYAX RYLR890 LoRa radio module - used to transmit experimental data.
- BEITIAN BN-220 GPS - send location data will be used to recover the CanSat.
- BMP180 Barometric sensor - records temperature, pressure, altitude data.

Additionally, we will use a corresponding ground station, built on top of an additional Arduino module. The ground station will contain a matching radio module in addition to a LCD display for showing the data.

These listed components will work in junction as demonstrated in the figure below:

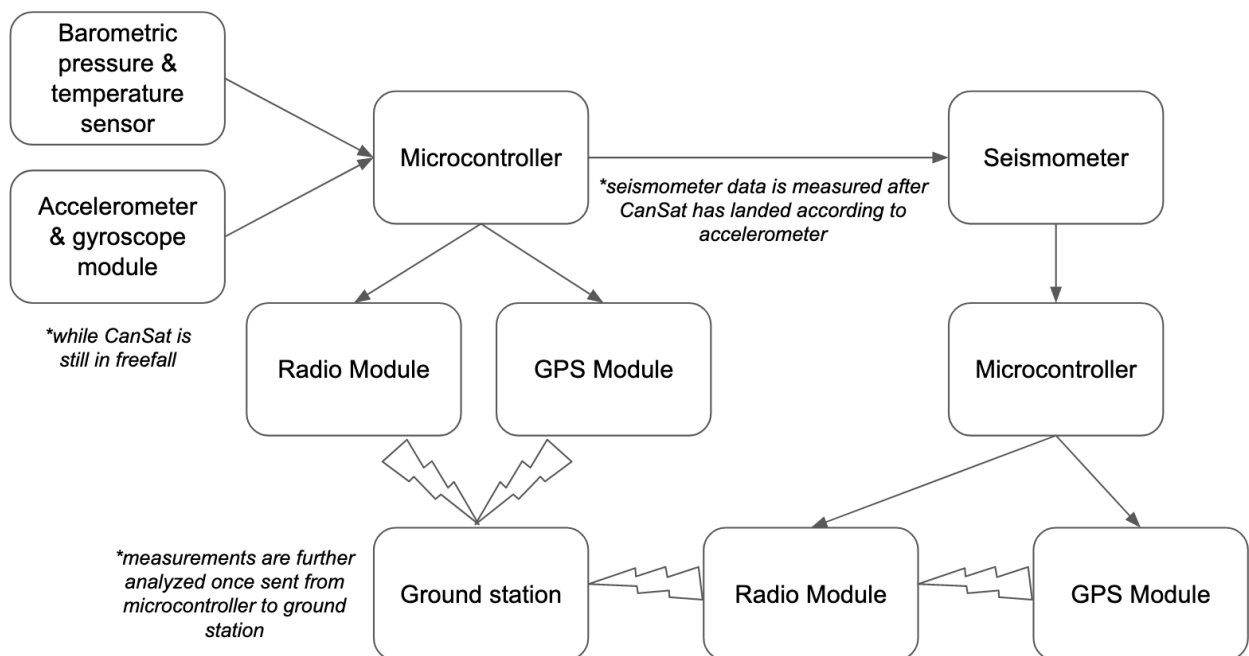



## 2.2 Mechanical/structural design

For our CanSat, we went through several design iterations. For the first one, we used the standard shell off the Canduino website, and assembled it as shown in the following picture. Our first iteration did not take our seismometer into consideration - we wanted to build the basic CanSat and get the radio transmission working before considering how to fit in the seismometer. At this point in time, we believed that the seismometer would take up a large amount of space.

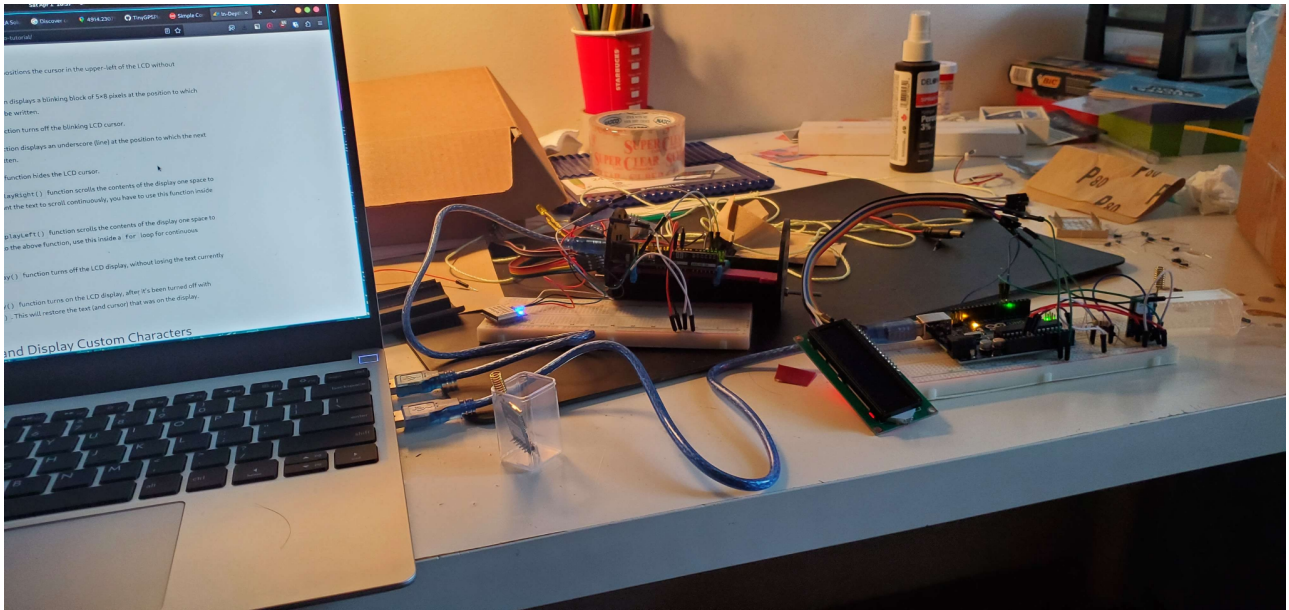

We began designing the CanSat with the priority of fitting our seismometer inside with ample space. We switched to using an Arduino Nano, and we went through several iterations.

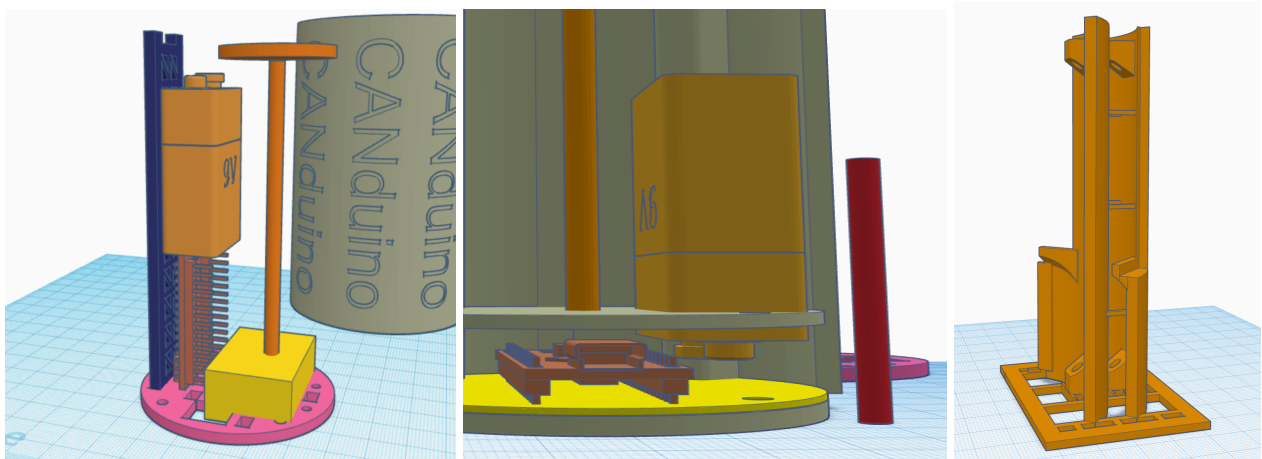

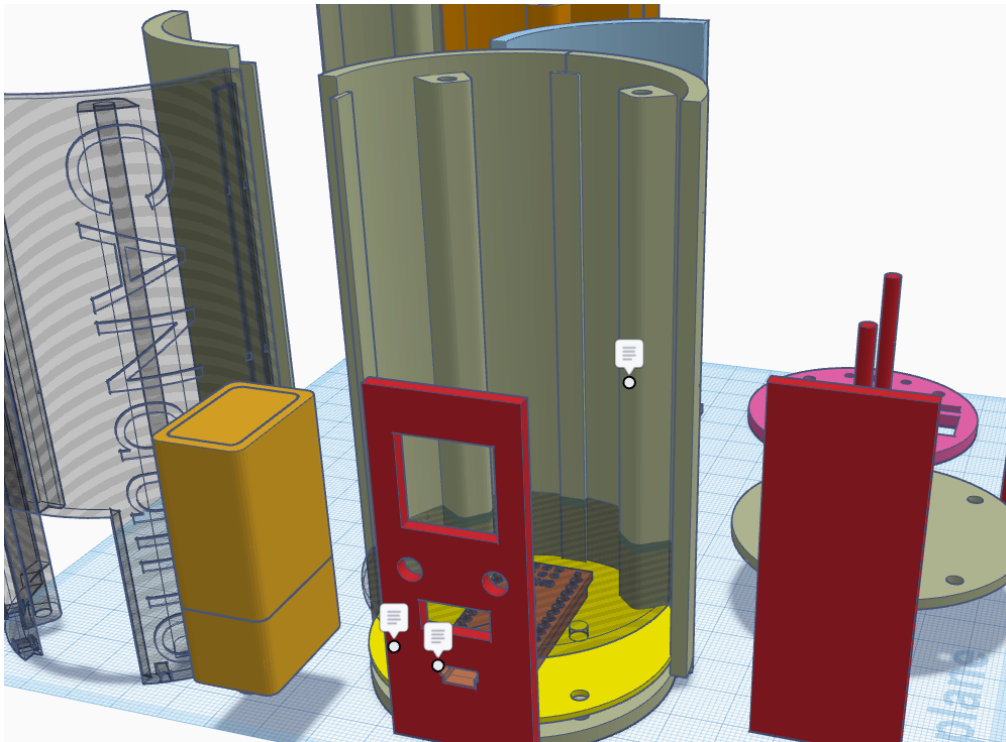

However, as testing went on, we found that the original design for our seismometer would not be functional, so we adjusted to a version that only requires a gyroscope. Here is our final design:

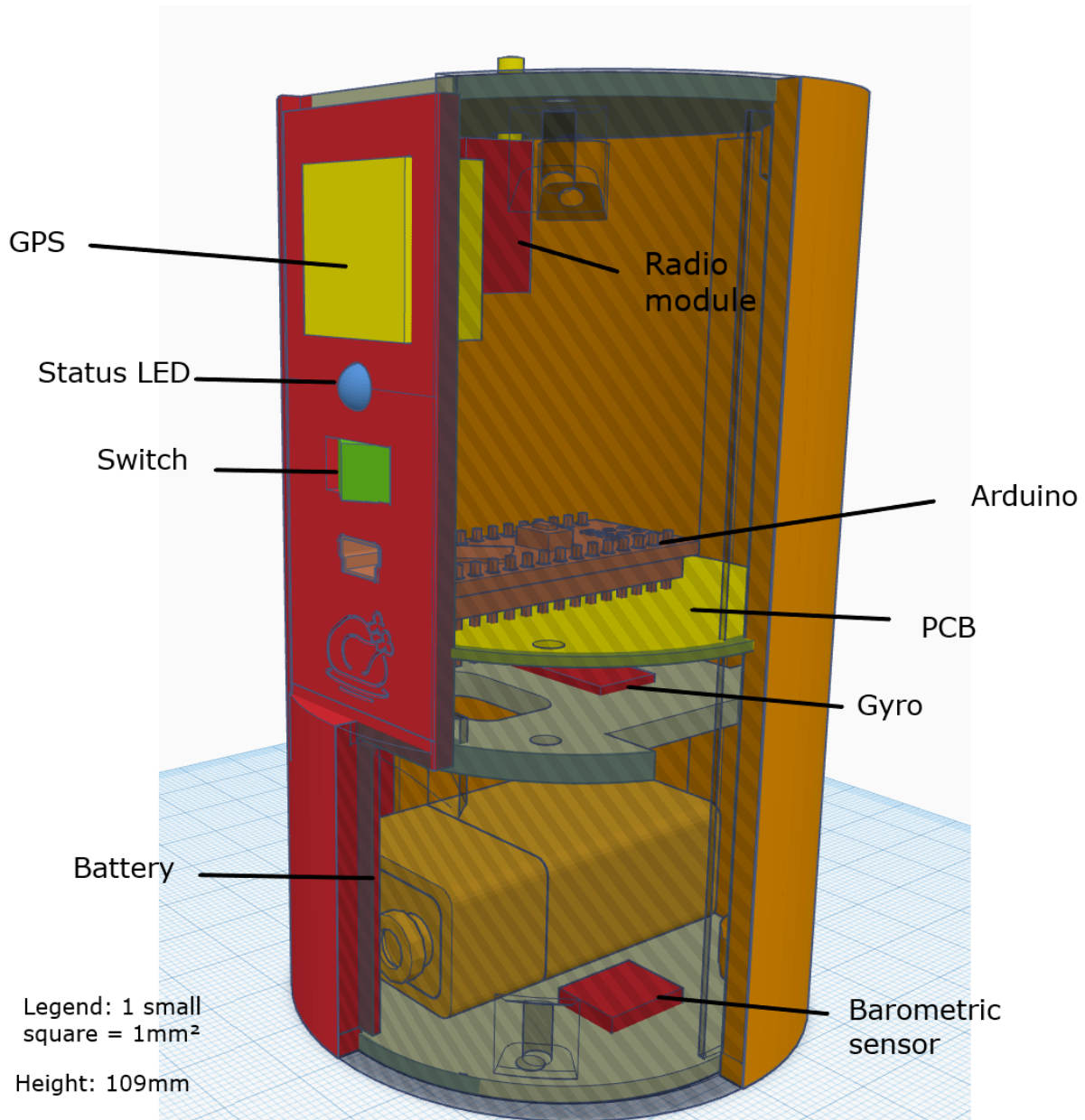

We modified the original shell to expose the metal rods that run throughout the CanSat instead of having them fully encased. This allowed us to be very flexible with assembly and able to vertically position platforms using nuts, as shown with the PCB and gyroscope platform. It also allowed for better cable management. Additionally, we added and printed a flat cutout in order to keep the arduino nano port accessible. We also decided to use the flat impression to hold our GPS, status LED, switch, and logo.

The barometric sensor will continuously record pressure and temperature measurements during descent. It is placed on the bottom so it can be exposed to air and shielded by the rest of the CanSat. The battery provides power, and can be replaced by removing the bottom panel. The PCB connects all the components to the Arduino microcontroller. The GPS records position, aiding with retrieval. The



gyroscope detects whether or not the CanSat has landed, and also acts as the seismometer. All data is sent using the radio module.

In total, the following will be used for the construction of the CanSat:

- Parachute tarp
- Parachute twine
- Eye bolt
- On/Off switch
- Hook up wire
- 9V battery adaptor
- LED
- BN-220 GPS Module
- BMP 280 (Barometric pressure/temp sensor)
- MPU 6050 (Gyroscope and Accelerometer)
- Seismometer
- 915 MHz RF module
- Antenna (radio amplifier)
- Arduino UNO R3
- Arduino shield
- Various 3D printed parts



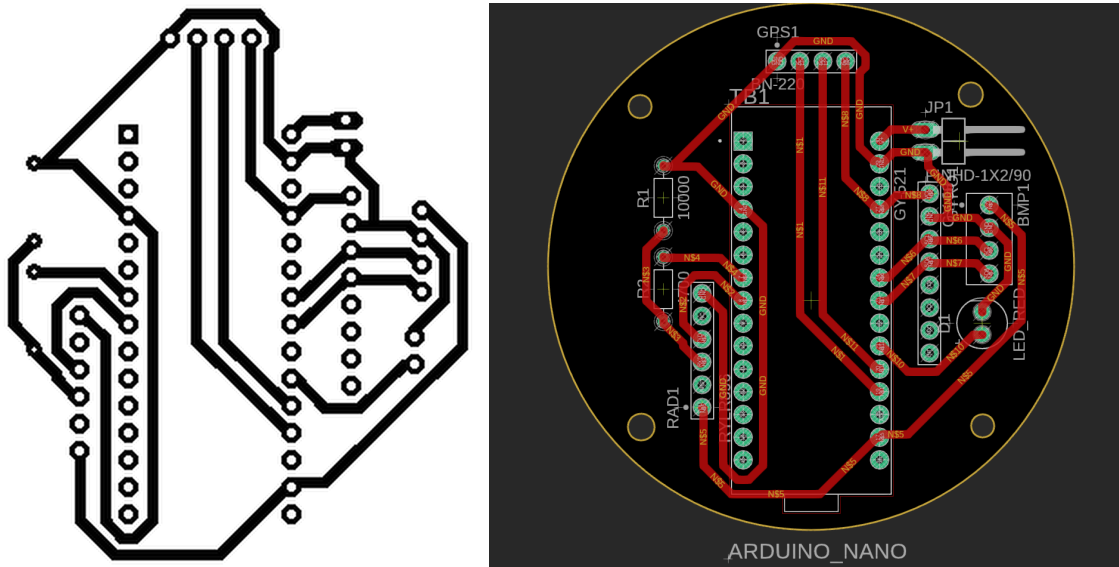

*The PCB layout of the CanSat derived from the circuit schematic*

## 2.4 Software design

For our software, we will be programming the Arduino Nano, with the assistance of several libraries to control the BMP180, GPS, and gyroscope. We will also be including libraries to assist with denoising the output for our gyroscope.

The program begins by testing all of its sensors. In case of failure, the status LED will blink an appropriate error code; otherwise, the LED will remain lit, indicating normal functionality. In order to use the GPS and radio simultaneously, the SoftwareSerial library is used to emulate serial ports for communication through those sensors. The sensors will record data approximately twice per second, sending it to the ground station for processing.

All the data from the sensors will be sent as a large CSV string, with a constant order that may be interpreted by the ground station. To save memory, C strings are used, so care must be taken to avoid a buffer overflow. The ground station will split the string into its relevant components and will also be responsible for analyzing the data and the materials present indicated by it.



The logic behind the CanSat can be seen in the flowchart listed below:

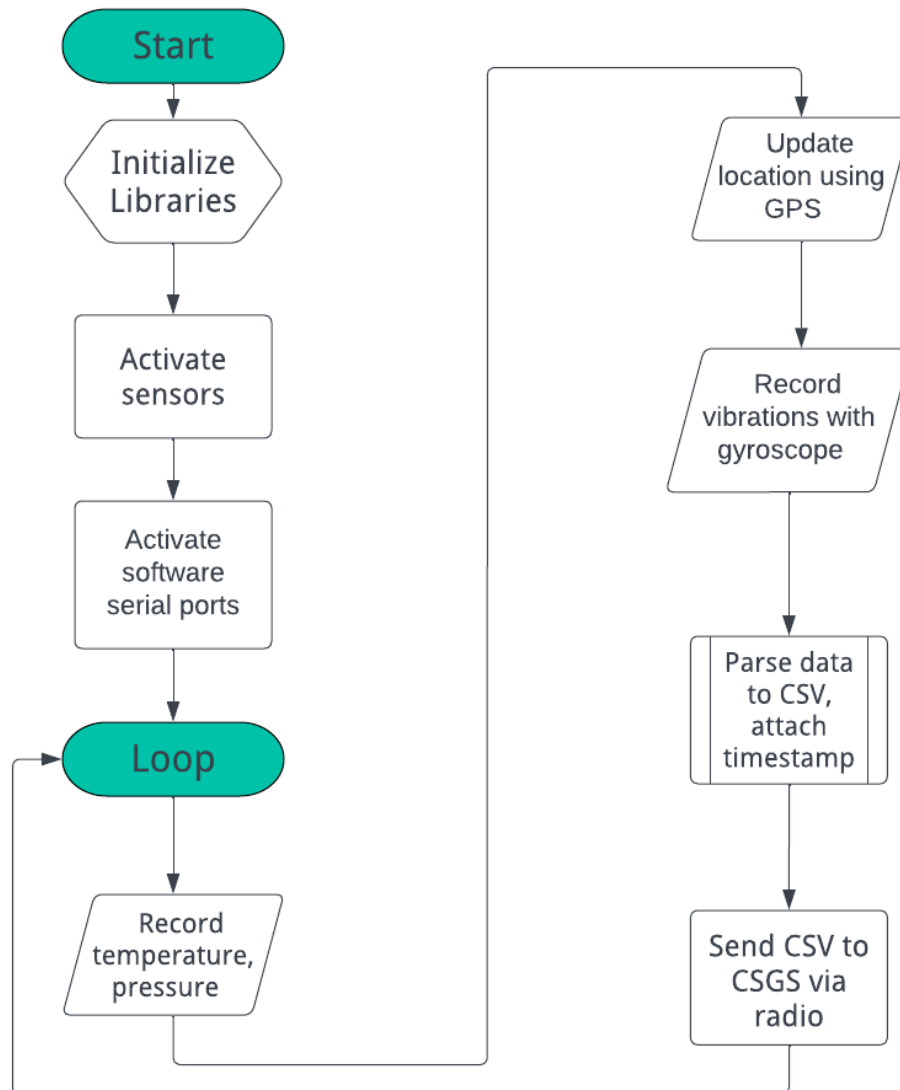

## 2.5 Recovery system

The recovery system used will involve a parachute and a GPS tracking system directly installed into the CanSat. The parachute will unfurl after it is detached from the rocket during its descent to ensure minimal risk of damage to the CanSat and minimal influences on the data gathered. The parachute will be constructed from the provided orange tarp, allowing high visibility, and will be affixed to the CanSat using twine. The CanSat will contain a GPS system that will be used for its retrieval after it has landed.

The expected flight time will be around 1.5 minutes.



### **3 PROJECT PLANNING**

#### **3.1 Time schedule of the CanSat preparation**

*February 20, 2023:* Critical Design Report due

*March 10, 2023:* Materials decided/ordered, final design decided, components are tested/verified

*March 17, 2023:* Landing system completed, pressure and temperature sensors and arduino installed

*March 24, 2023:* Parachute system completed, rough code is completed

*March 31, 2023:* Seismometer system completed

*April 5, 2023:* Rough prototype is assembled, code is debugged

*April 13, 2023:* Testing is completed

*April 20, 2023:* Final changes completed, CanSat finalized

#### **3.2 Resource estimation**

##### **3.2.1 Budget**

Basic CanSat kit (1): \$136.56

Metal Rods (21): \$19.99

REYAX RYLR896 Lora Module (2): \$67.74

BN-220 GPS Module (1): \$26.98

Nylon Fabric (1): \$14.40

Misc/Taxes: \$6.41

**Total:** \$272.08

##### **3.2.2 External support**

We have received support from Mr. Lam—an Eric Hamber physics teacher and our supervisor—for classroom use, outreach avenues and potential funding. Eric Hamber electronics teacher Mr. Macdonald has also allowed us to use some electronics classroom material to build out CanSat, and Mr. Ark—Eric Hamber computer science teacher—has further generously given us an arduino to use. Other science teachers



were and are available for external advice or support as well. Professor Ian Butler at McGill University, similarly provided support through advice via email.

We have not received any external financial report or sponsorships.

### 3.3 CanSat Testing Process

- Parachute Ability to Withstand 50N of Force: Test by using newton scales to ensure the connection between the parachute twine, eye bolt, and CanSat can withstand 50N of force

Test results: Complete - April 16, 2023 - multiple Newton spring scales were linked in parallel to create 50N worth of force. We connected the parachute, twine, and eye bolt system to the CanSat and pulled the parachute one way and the CanSat the other way. The connections held.

- CanSat Ability to Withstand Acceleration of up to 20g: Test by attaching to a rope and swinging it around to ensure it survives 20g

Test results: Complete - April 16, 2023 - Using the formula for centripetal acceleration  $a_c = v^2/r$ , and using a one-meter long rope, we can calculate the tangential velocity to be equal to (assuming  $g = 10\text{m/s}^2$ ):  $v^2 = 20 \cdot 10 / 1 = 200$ . Therefore,  $v = \sqrt{200} = 14.142 \text{ m/s}$ . Using the formula  $v = \omega r$ , we converted tangential velocity into revolutions per second as follows:  $\omega = 14.142 \text{ rad/s}$ . We then converted this into revolutions per second:  $14.142 / 2\pi = 2.2508 \text{ revolutions/second}$ . Implementing this number into our testing, we attached the CanSat to a one-meter long rope and swung it around in a circle until it reached about 3 revolutions every second. This subjected the CanSat to a force even greater than 20G, but fortunately, all systems functioned normally.



## 4 OUTREACH PROGRAMME

### 4.1 Brief Overview

For our outreach program, we made presentations to an elementary school class and a secondary school class, detailing our brainstorming process, the construction, and the testing of the CanSat. Each of these presentations are planned to last for approximately 20-30 minutes, not counting additional questions or activity time. Further publicity efforts will be extended through online media like an Instagram account, TikTok, Youtube, Reddit, and GitHub. We also designed a logo that fits with our team name, "TurkeyBurkey", to be used alongside our media and outreach efforts.

### 4.2 Presentation Outlines & Resources

**April 17, 2023: Graham Bruce Elementary - Gr. 5 Class** (Teacher: Ms. Conley - [tconley@vsb.bc.ca](mailto:tconley@vsb.bc.ca))

- *CanSat and Team Introduction:*
  - Brief introduction of what the CanSat competition is & CanSat requirements
  - Introduction of our team and roles/interests
- *What is a CanSat?*
  - Description of a CanSat – components, materials, functions
- *Design Your Own Cansat (or other space contraption) & Share:*
  - Direct question towards students in groups
  - If you could construct a CanSat, what would it look like? How would it function? What materials would you need?
  - Bonus: consider cost, energy, feasibility, size etc.
- *Share Design and Building process:*
  - Time for students to share their designs and explain their processes
  - Connection with our own designing and building process - (many factors like cost, energy, feasibility, size, weight etc.)
- *Conclude:*
  - Ask students what their main takeaways were from the design process of engineering
  - Answer any questions that the students raise
- Key Points:
  - Ensure that all topics are presented in an engaging manner for a younger audience
  - Simplify descriptions and explanations
  - Be prepared for a wide range of questions

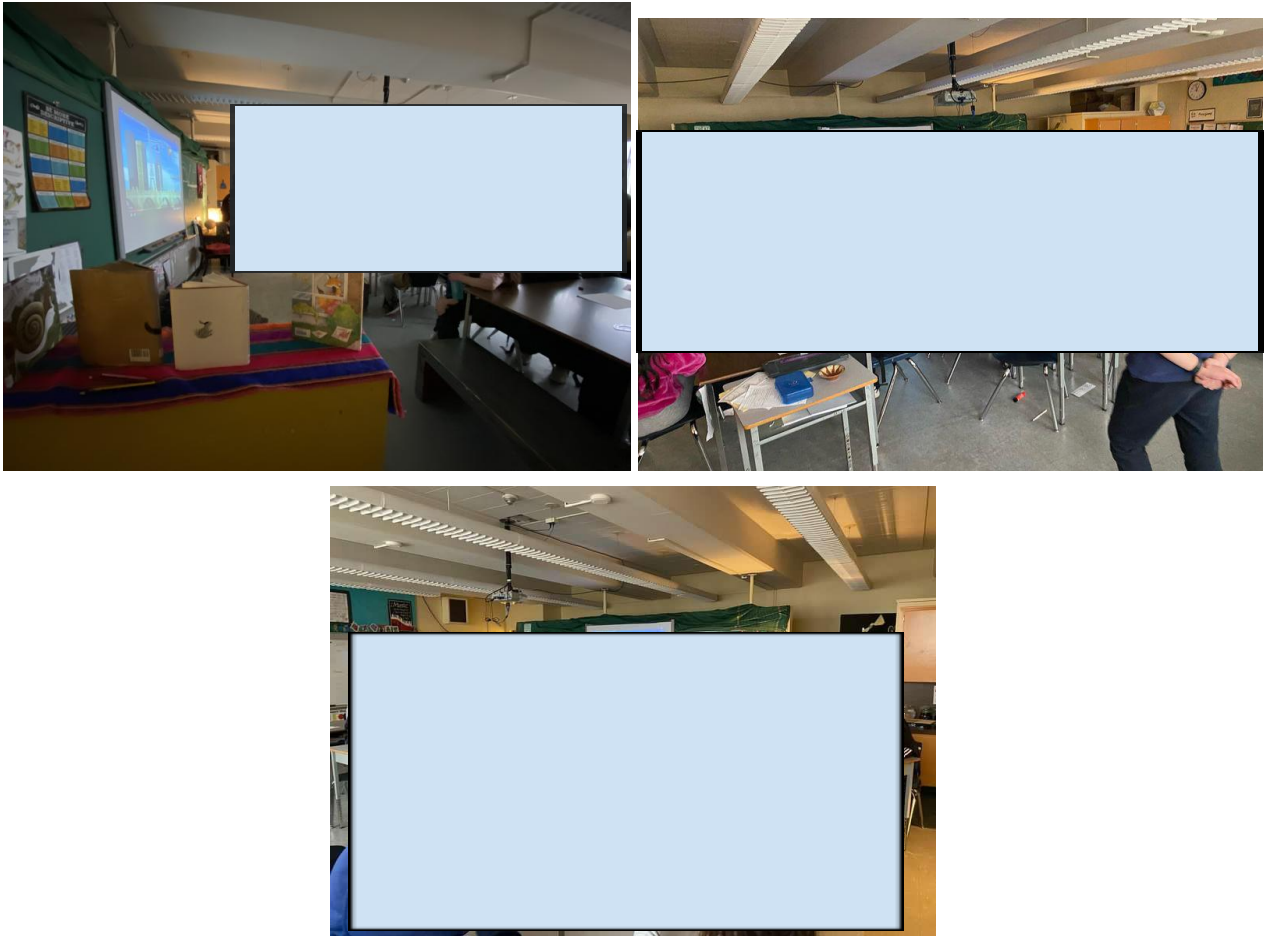

*Photographs of our presentation to a Grade 5 class at Graham Bruce Elementary*

**April 18, 2023: Eric Hamber Secondary School - Challenge-Studio Gr. 9 Science Class** (Teacher: Ms. Thi - [jthi@vsb.bc.ca](mailto:jthi@vsb.bc.ca))

- *CanSat and Team Introduction:*
  - Brief introduction of what the CanSat competition is & CanSat requirements
  - Introduction of our team and roles/interests
- *What is a CanSat?:*
  - Description of a CanSat - requirements in coordination with the guidelines
  - Process for entering the competition
- *Design Process & Construction:*
  - Resources and external support
  - Design process and Critical Design Report
  - Construction and Testing
- *Event Details:*
  - Event schedule and preparation for the event
  - Conclusion and Takeaways



- Key Points:
  - Provide more descriptions on how the competition works and registration
  - Descriptions can be more detailed but should still be understandable
  - Focus on the design and construction aspect - use a variety of visuals/videos

### **April 19, 2023: Online Zoom Presentation**

- online presentation open to the general public with promotion through our social media accounts
- similar in format to the CHST 9 presentation with time for questions at the end
- Key Points:
  - Provide information on how the competition works and registration details
  - Focus on the design and construction aspect - use a variety of visuals/videos
  - Emphasis on promotion and creating interest for the CanSat competition

**Email:** hampercansat@gmail.com

**Instagram:** @turkeyburkeycansat

**TikTok:** @turkeyburkeycansat

**GitHub:** <https://github.com/nuggetbucket54/CanSat>



## 5 SPECIFICATIONS

Characteristics	Figure (number + units)
Height of the CanSat	115 mm
Mass of the CanSat	350 g
Diameter of the CanSat	66 mm
Length of the recovery system	230 mm
Flight time scheduled	90 seconds
Calculated descent rate	8 m/s
Power consumption	13.47 mWh
Total cost	\$291.07

### 5.1 Preliminary power budget

The components and their expected power usages are as follows:

Device	Voltage (V)	Current (mA)	Power (mW)
BN-220 GPS module	5.0	50	250
MPU6050	3.3	3.9	12.87
BM180	3.3	1	3.3
REYAX RYLR896 Lora Module (Transmitting)	5.0	43	215
REYAX RYLR896 Lora Module (Receiving)	3.3	16.5	54.45
LED	3.3	10	33
Total power (sum of all)			568.62



Using a generic 9V battery rated for 2400 mAh, and applying the formula for calculating battery run time:  $10 \times (\text{battery capacity in amp hours}) / (\text{load in watts}) = 10 \times (2400) / (568.62) = 42.207$  hours.

**The CanSat will run for approximately 42 hours.**

*On behalf of the team, I confirm that our CanSat complies with all the requirements established for the 2023 European CanSat competition in the official Guidelines,*

*Signature, place and date:*

Ryan Cheng, Vancouver, April 16, 2023

Mathew Fu, Vancouver, April 16, 2023

Tyler Chen, Vancouver, April 16, 2023

Bowen Yuan, Vancouver, April 16, 2023

Eric Li, Vancouver, April 16, 2023



# CANSAT

## TEAM TURKEYBURKEY

Tyler Chen, Ryan Cheng, Mathew Fu,  
Eric Li & Bowen Yuan

# Table of contents

## **Mission Objectives**

Team Introduction & Mission Details

01

02

## **CanSat Description**

Components, Design & Recovery System

## **CanSat Logistics**

Resources, Budget & Testing

03

04

## **Outreach Programme**

Social Media & Outreach Presentations

A dark space background featuring a large, reddish-brown planet in the center and several grey, rocky asteroids scattered throughout. A white square is centered in the upper half of the image.

**01**

# Mission Objectives

Team Introduction & Mission Details

# Primary Mission



Create a CanSat to be launched at 1000m altitude and a ground station counterpart



- Meets the requirements for volume, size, weight, and energy



- Measure air pressure, temperature, and GPS location while descending and transmit live data to ground station

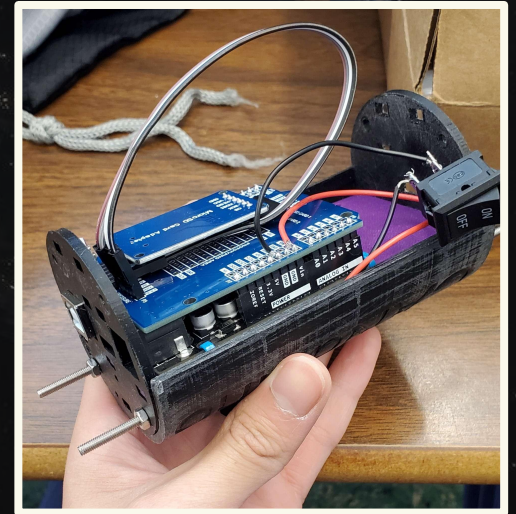

# Primary Mission

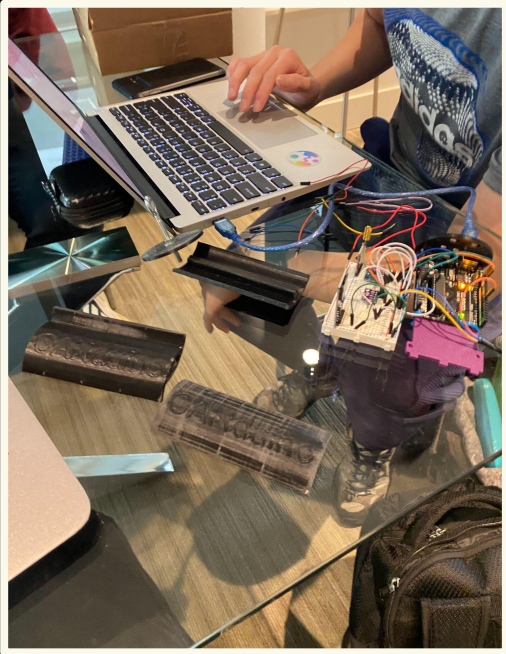

Create a CanSat to be launched at 1000m altitude and a ground station counterpart



- Maintain structural and functional integrity while under the forces of launch/freefall



- Equipped with a parachute to not exceed 11 m/s terminal velocity
- Include an appropriate recovery system

# Secondary Mission

Measure and record seismic activity upon landing using an implemented gyroscope

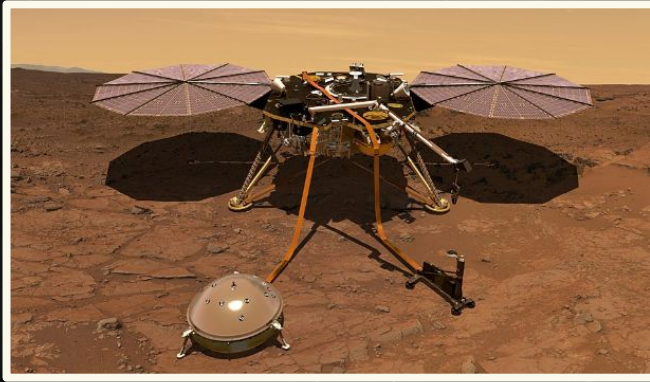
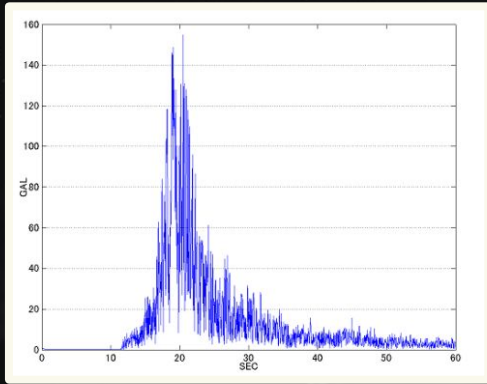

# Scientific Reasoning

Earthquakes can cause devastating damage to human constructions

## Importance

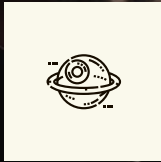

Inspiration from NASA's rover INSIGHT that measured seismic activity on Mars

## Precedence

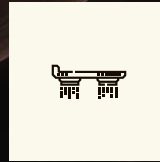

Inexpensive and approachable method to measure seismic activity of alien planets

## Feasibility

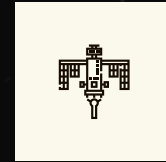

# Mission Process

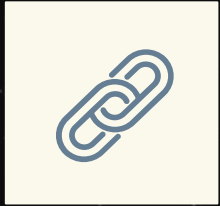

## Connect

**Connect** ground station and satellite during freefall and landing



## Measure

**Measure** and record vibrations and tremors upon landing

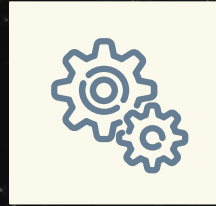

## Convert

**Convert** readings to Shindo scale used by Japan Meteorological Agency



## Display

**Display** the converted data at the ground station

The background of the slide is a dark, space-themed image. It features a large, reddish-brown planet, likely Mars, in the upper right quadrant. The rest of the scene is filled with numerous grey, irregularly shaped asteroids of various sizes scattered across the black void of space.

02

# The CanSat

Components, Design, Recovery Process



**02.1**

**Mechanical &  
Structural Design**

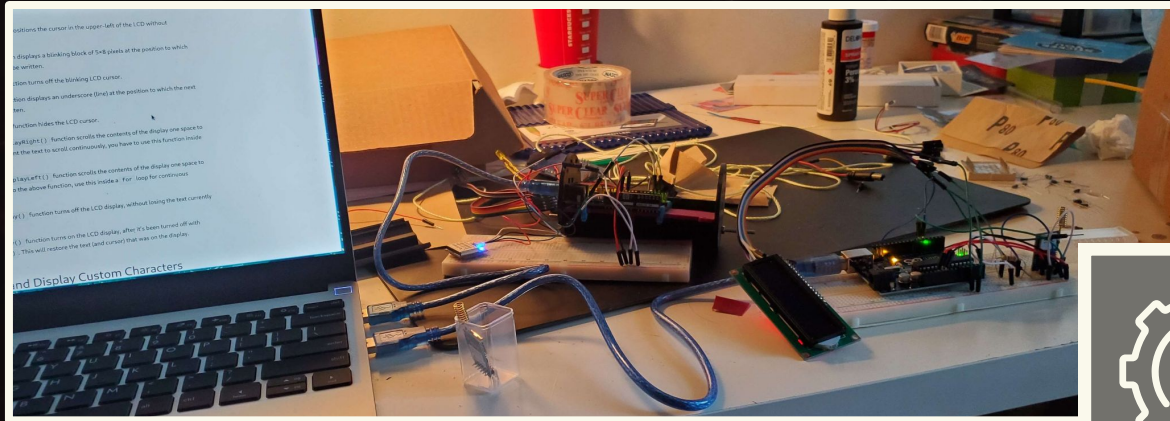

- Several design iterations
- **First iteration:** standard Carduino shell and assembled accordingly
  - Initial basic CanSat to test radio transmission, design components and volume
  - did not incorporate seismometer (believed to be large)

- Began designing with priority of fitting seismometer inside with ample space
- Switched to using an Arduino Nano, and went through several iterations

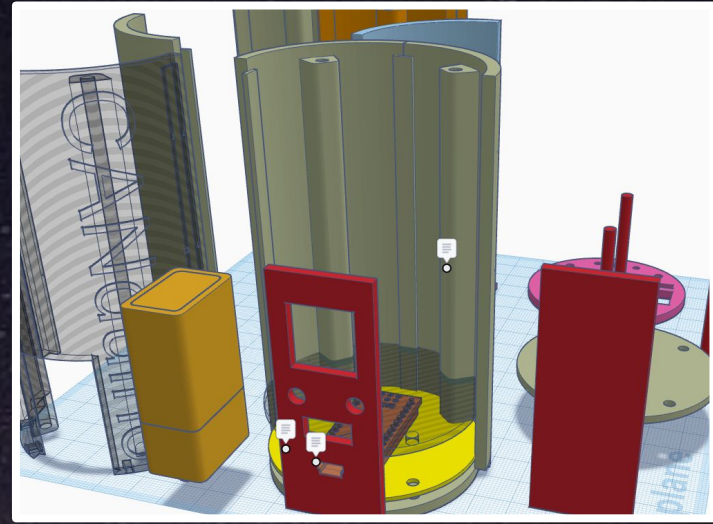

# Design Process

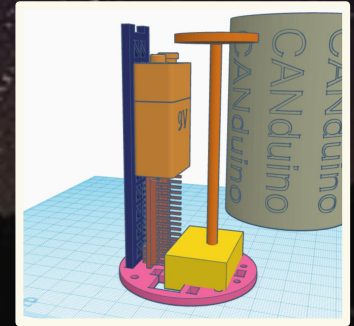
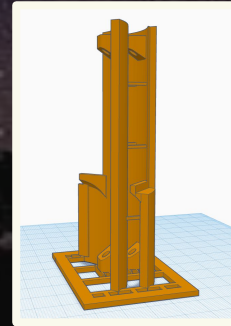
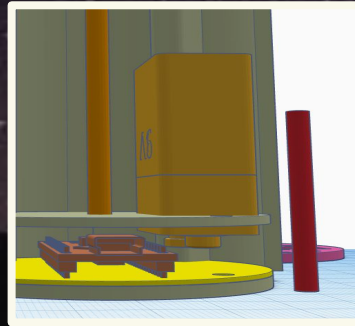

- Discovered original design for our seismometer would not be functional through testing
- Adjusted to version that only requires a gyroscope

# Design Adjustments

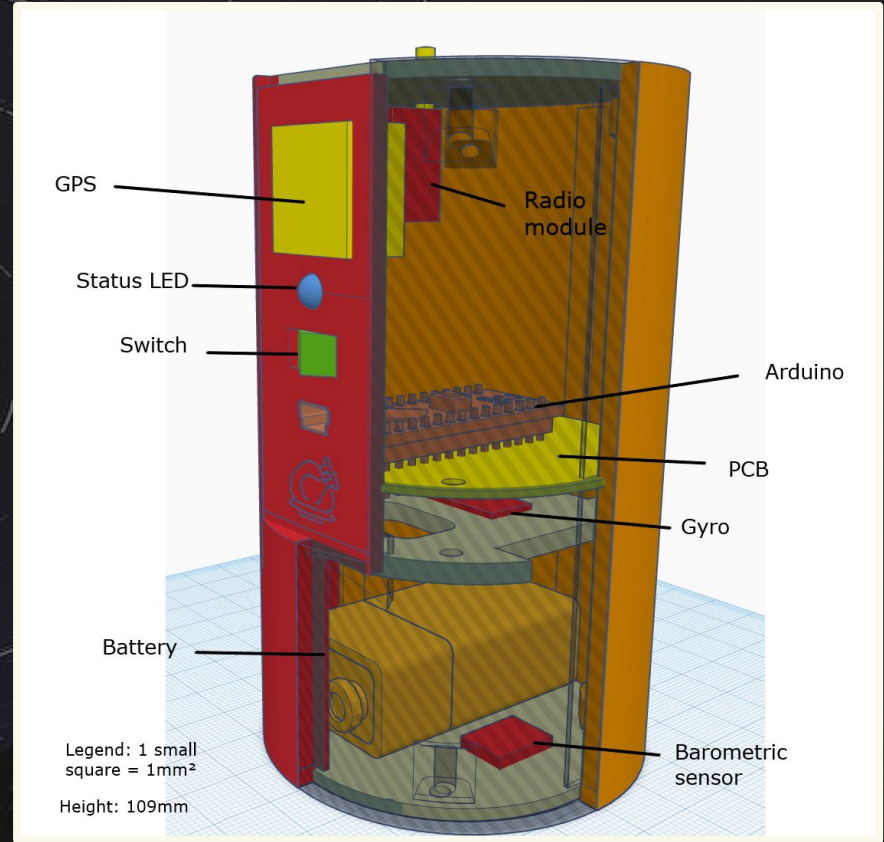

# Final Design

- Barometric sensor continuously records pressure & temperature
- Battery provides power (can be replaced by removing bottom panel)
- PCB connects all components to Arduino microcontroller
- GPS records position, aiding with retrieval
- Gyroscope indicates if CanSat has landed, and also acts as seismometer
- All data is sent using radio module

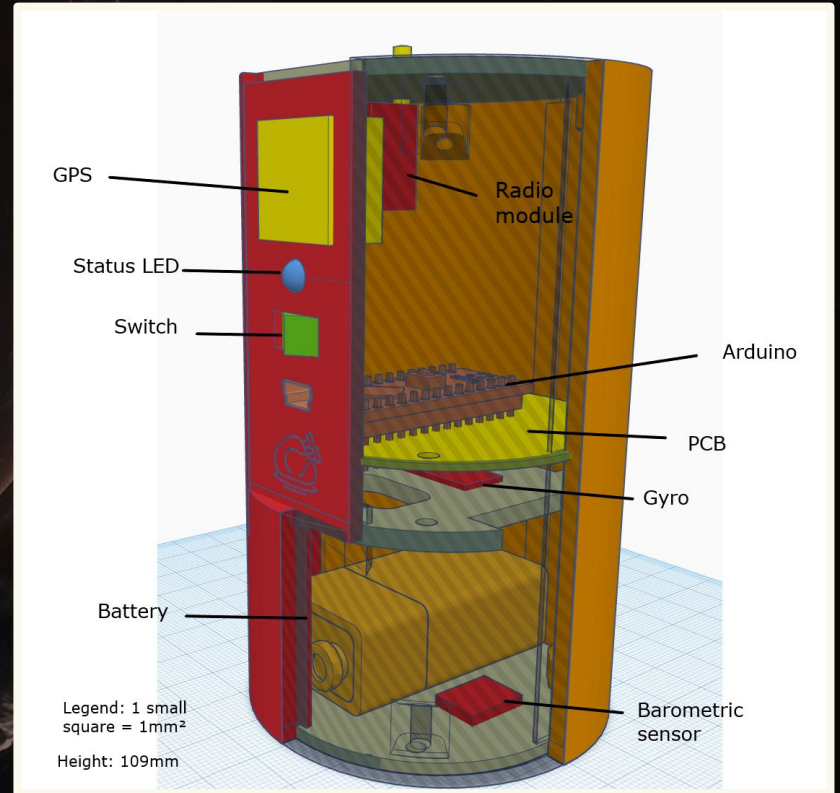

# Components of Our CanSat

- Parachute tarp
- Parachute twine
- Eye bolt
- On/Off switch
- Hook up wire
- 9V battery adaptor
- LED
- BN-220 GPS Module
- Various 3D printed parts
- MPU 6050 (Gyroscope and Accelerometer)
- 915 mHz RF module
- Arduino NANO V3
- BMP180 (Barometric pressure/temp sensor)

# Electrical Design

Gyroscope

GPS Tracker

Barometric Sensor

Radio

Arduino

Power switch

Status LED

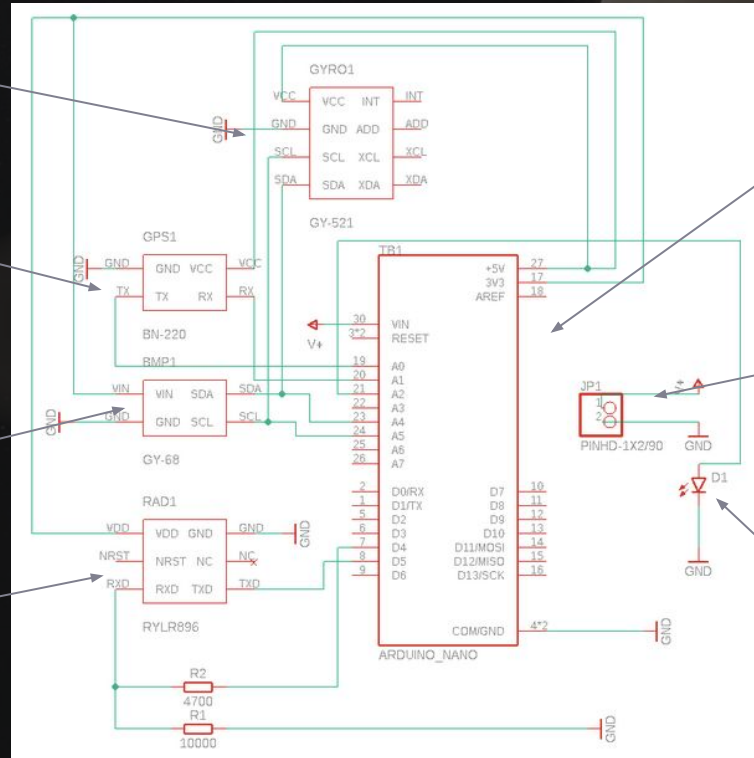

# Past PCB designs

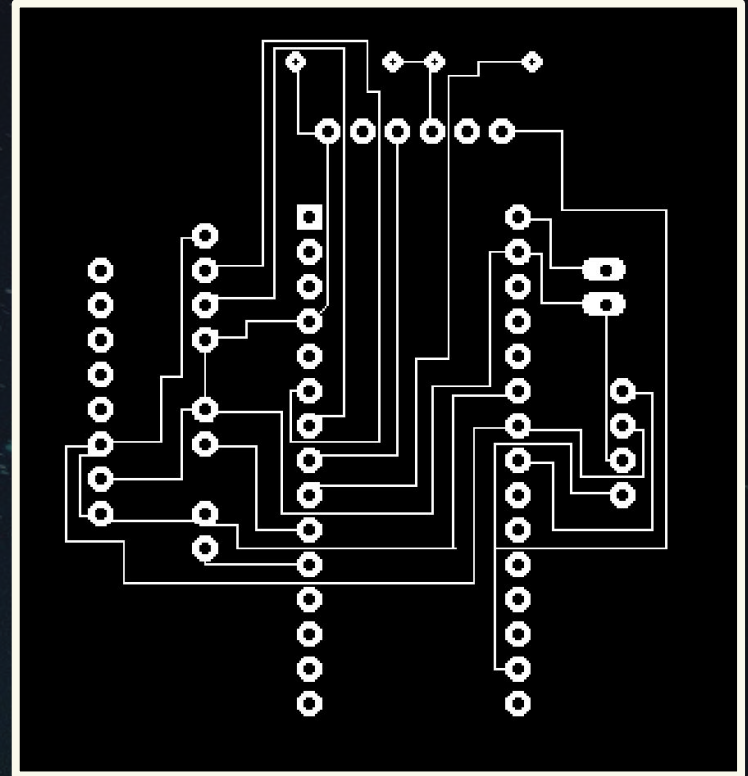
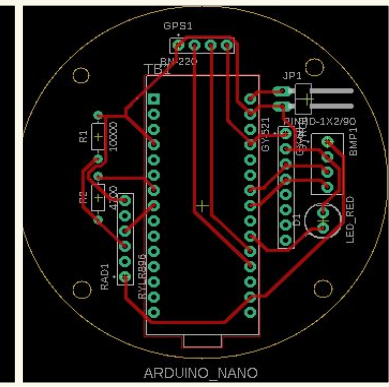
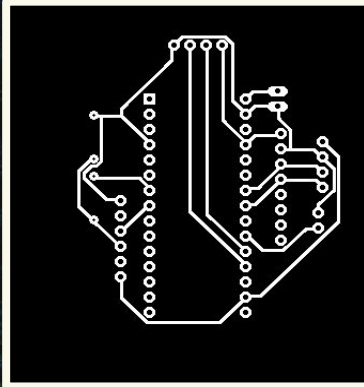
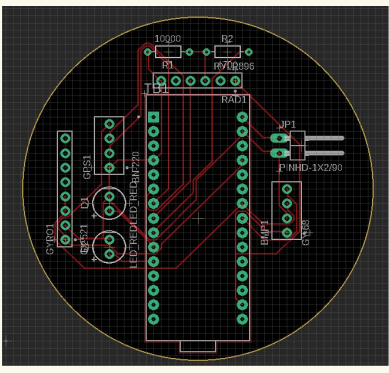
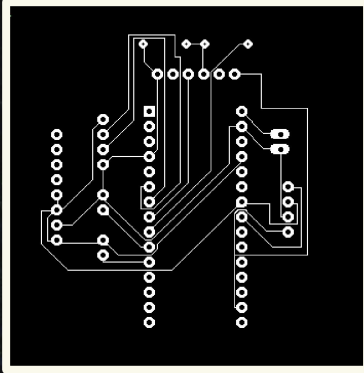

# Etching the PCB



Transfer PCB layout onto copper sheet



Eat away unwanted copper using acid

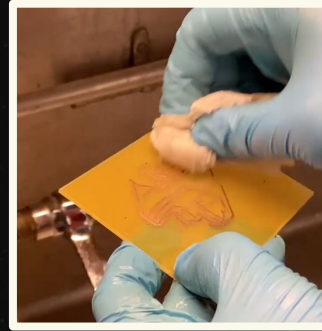



Dissolve ink from printed PCB layout

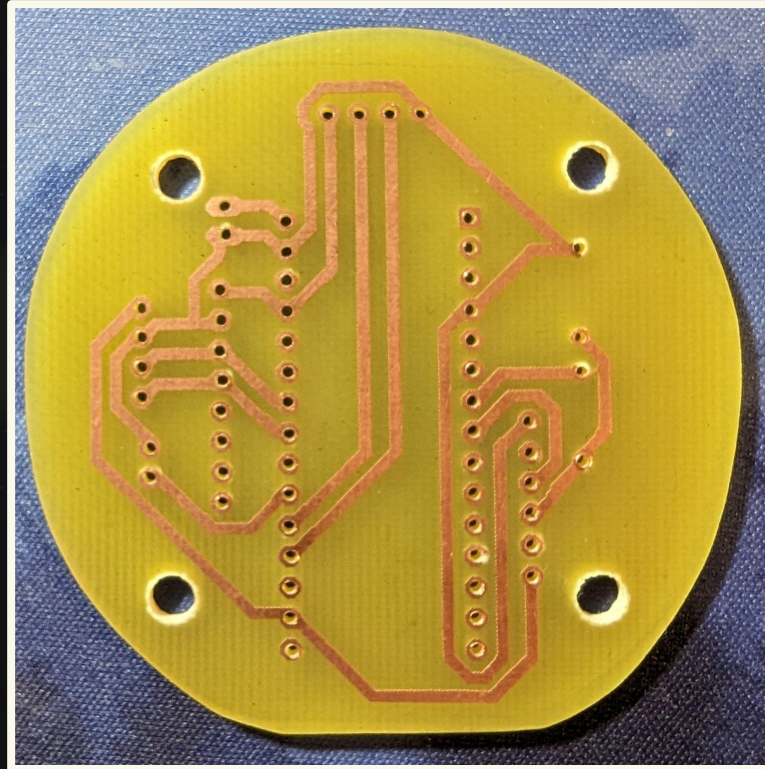

Sand and drill holes as needed

# Finished Product



A dark space background featuring a large, reddish-brown planet in the upper right and several grey, rocky asteroids scattered throughout. The text is overlaid on this scene.

**02.3**

**Software Design**

# Difficulties with seismometers

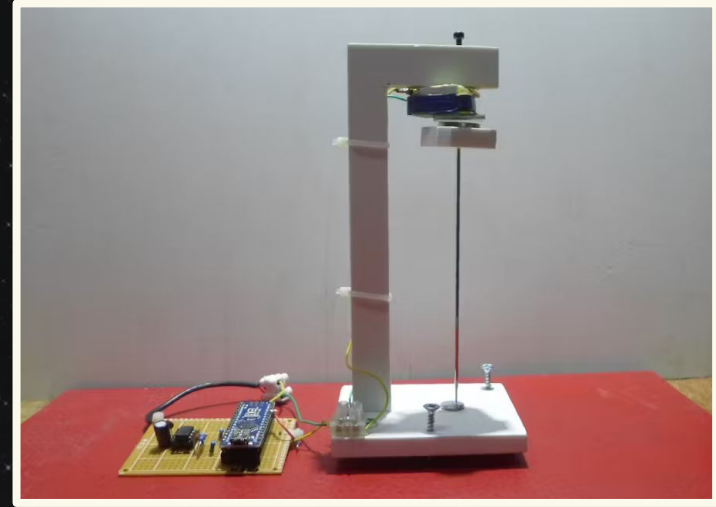
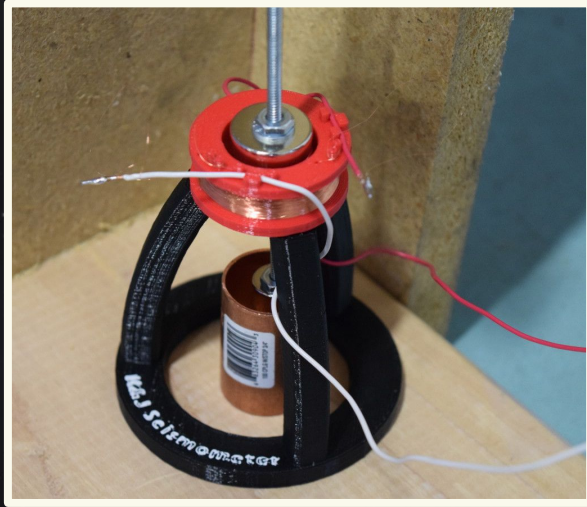

Huge amounts of space needed for more common seismometers, requires completely vertical position

**Solution:** measuring  
raw acceleration  
values...

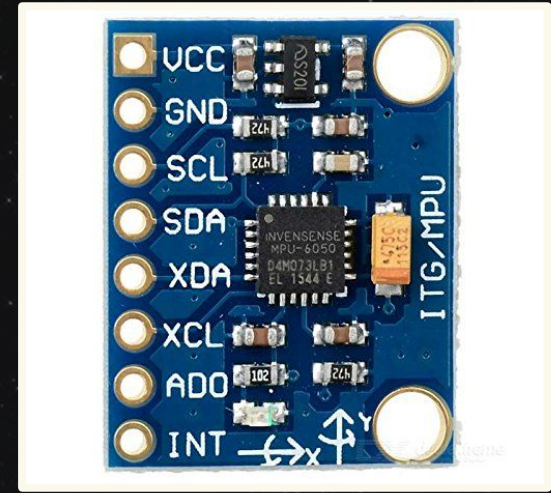
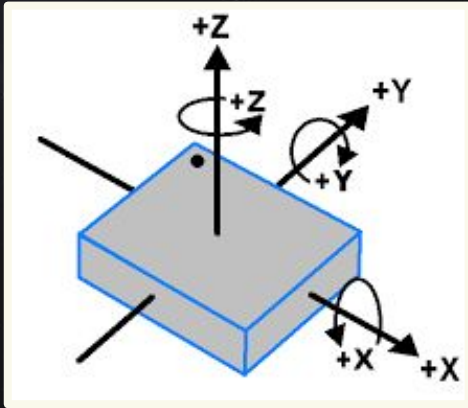

...and mathematically accounting  
for the angle of the CanSat  
(software solution!)

**01**

**Calculate X-, Y-, and  
Z- components of  
acceleration based off  
gyro angle**

*Completed through some trigonometry calculations*

The background of the slide is a dark space scene featuring a large, reddish-brown planet on the right side. Numerous grey, irregularly shaped asteroids of various sizes are scattered throughout the field of view, some appearing closer and larger, others further away and smaller. The overall lighting is dim, with the planet and some asteroids providing the primary light sources.

**02**

**Take multiple  
measurements within a  
short time period**

*In our case, 12 measurements for X, Y, and Z in 0.12 seconds  
(36 total values)*

**03**

# Apply a Fourier transform to the 12-sample dataset

*Separates data into a function with (theoretically)  
peaks for the system noise*

**04**

**Multiply Fourier transform  
by various constants  
(determined by JMA)**

*Eliminates the noise associated with the module*

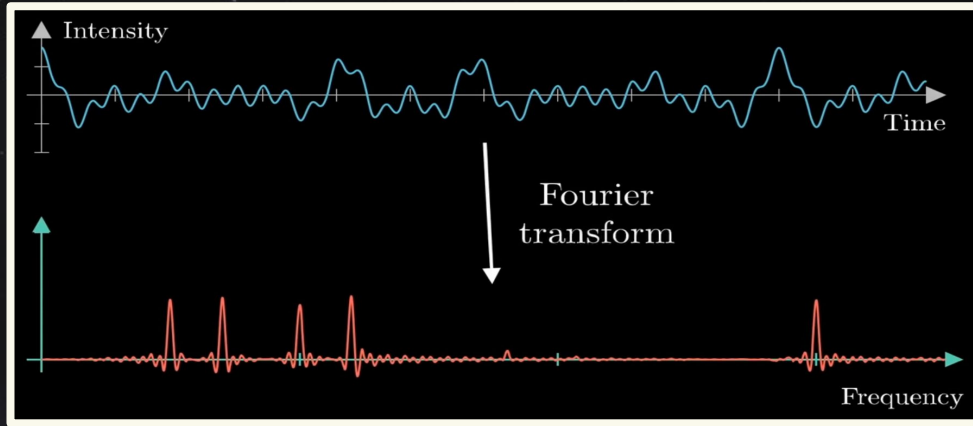

*(top) Fourier transform of an example function*

*(bottom) rightmost peak (associated to some kind of noise) is flattened*

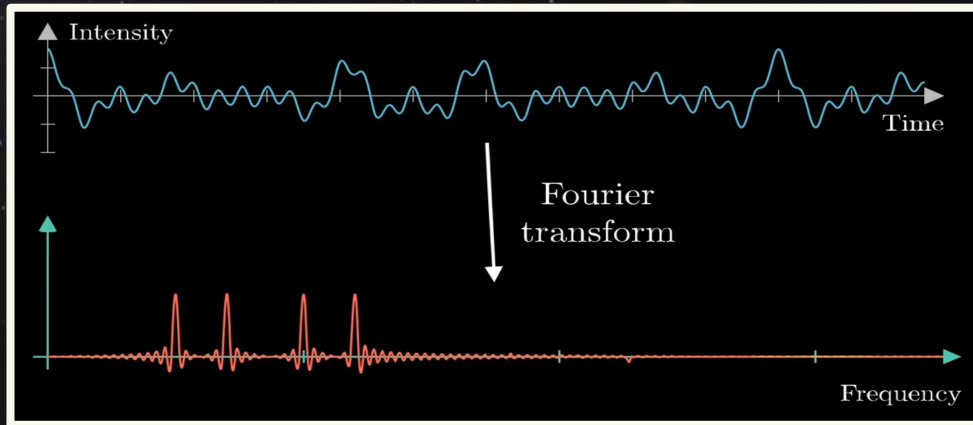

05

# Perform an inverse Fourier transform on the transformed dataset

*Converts the “filtered” data back into a format representing the initial measurements*

A dark space background featuring a large, reddish-brown planet on the right side, surrounded by numerous grey, rocky asteroids of various sizes scattered across the field of view.

**06**

**Synthesize these components  
into a single vector**

07

## Convert values of the vector into the Shindo Scale

*Using formula:*

$$\text{Intensity} = 2 \log a + 0.94$$

*(derived from JMA)*

# Shindo Scale

Intensity	Effect on People	Acceleration (m/s <sup>2</sup> )
...		
2	Perceptible to most people indoors. Awakens light sleepers.	0.06 - 0.20
3	Perceptible to everyone indoors. Frightens some people.	0.20 - 0.60
4	Frightens most people. Some seek escape. Awakens most sleepers.	0.60 - 1.10
5	Most people try to escape from danger by running outside. Some people find it difficult to move.	1.10 - 2.20
...		

03

# CanSat Logistics

Resources, Power Budget & Testing



# Power Budget

Device	Voltage (V)	Current (mA)	Power (mW)
BN-220 GPS module	5.0	50	250
MPU6050	3.3	3.9	12.87
BM180	3.3	1.0	3.3
REYAX RYLR896 Lora Module (Transmitting)	5.0	43	215
REYAX RYLR896 Lora Module (Receiving)	3.3	16.5	54.45
LED	3.3	10	33
Arduino NANO	9	25.5	229.5
Total Power (sum of all)			798.12

# Power Budget (cont.)

- Using a generic 9V battery rated for 2400 mAh, and applying the formula for calculating battery run time:  
$$10 \times (\text{battery capacity in amp hours}) / (\text{load in watts}) =$$
$$10 \times (2400) / (798.12) = 30.07 \text{ hours.}$$

**The CanSat will run for approximately 30 hours.**

**Power Consumption: 26.54 mWh**

# Testing Requirements 10 & 13

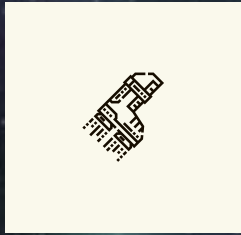

- **Parachute's ability to withstand 50N of Force:**

Test by using Newton Scales to ensure connection between parachute twine, eye bolt, and CanSat can withstand 50N of force

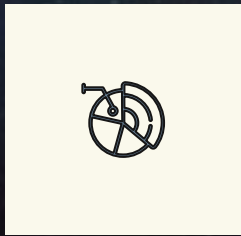

- **CanSat's ability to withstand acceleration of up to 20g:**

Test by attaching to a one-meter long rope and revolving it approximately 3 times per second, providing a centripetal force  $> 20g$

04

# Outreach Programme

Social Media & Outreach Presentations

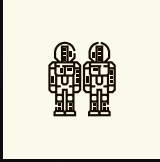

# Objectives

- Raise awareness about the satellite design process
- Spark interest in space exploration & engineering
- Detail registration & logistical procedures

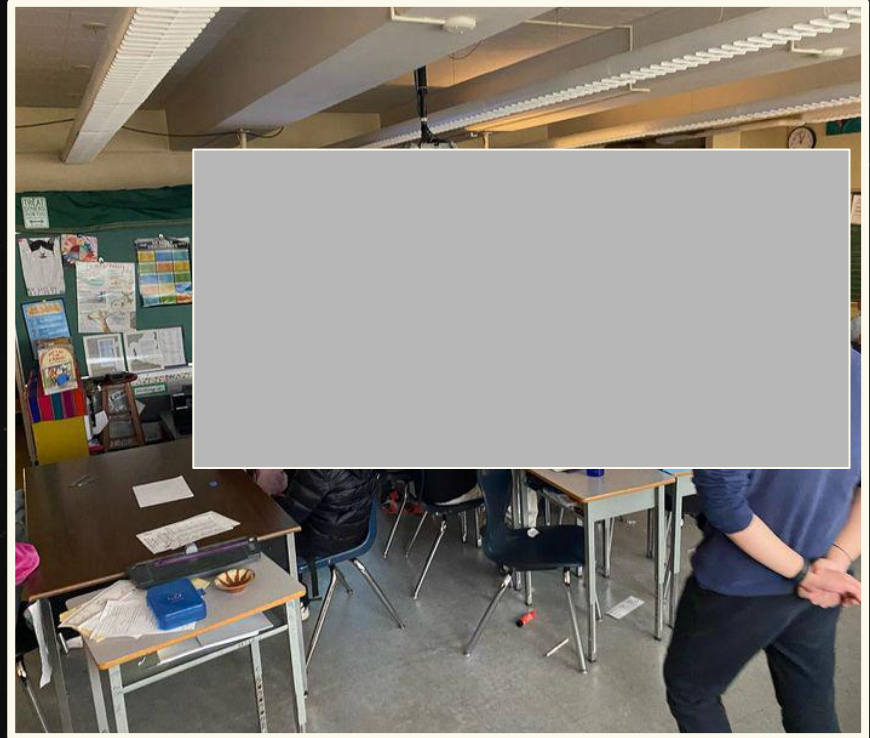

# Outreach Platforms

## In-Person

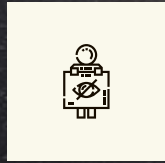

- Graham Bruce Elementary Grade 5 presentation
- Challenge-Studio Science Grade 9 presentation
- In-person conversations & interactions

## Online



- Public Zoom meeting & Q&A Session
- Challenge-Studio Teams announcement to 144 active members
- Social media: Instagram, Tiktok, Youtube, GitHub

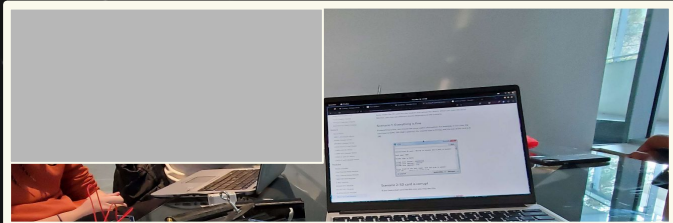
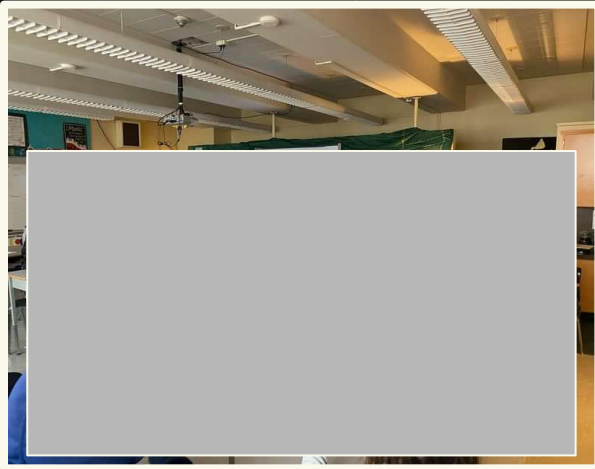

**Videos** 👍 Liked

Cansat team hard at wor... ▶ 0

Cleaning up PCB! ... ▶ 0

Printing new PCB design... ▶ 0

New PCB! #satisfying ▶ 0

PCB scrubbing ... ▶ 0

README.md

### Eric Hamber TurkeyBurkey CanSat

Sismometers are both useful and precise when it comes to measuring earthquakes or tremors. In humanity's ongoing efforts in interplanetary exploration, scientists have developed an abundance of methods to assess the inhabitability of celestial bodies. However, to our understanding, there is yet to be any way to remotely test seismic activities—one must conduct these tests on the surface of these planetary bodies.

Our CanSat converts the seismograph measurements to the Richter scale and determines the magnitude of the tremors and accelerations by the following:

- Maintain structural and functional integrity while under the forces of launch/freefall.
- Collect air temperature and pressure data during freefall.
- Measure and record vibrations and tremors upon landing.
- Maintain a stable radio connection during freefall and landing over which experimental data may be transmitted.
- Receive accurate and precise data.

#### Construction

The CanSat is built around the Arduino NANO V3. Etching and soldering our own circuit boards, these are the components used:

- MPU6050 gyro
- BME280 barometric sensor
- HY18090 LoRa radio transmitter/receiver

(left) circuit diagram, (middle) PCB schematic, (right) etched and drilled circuit

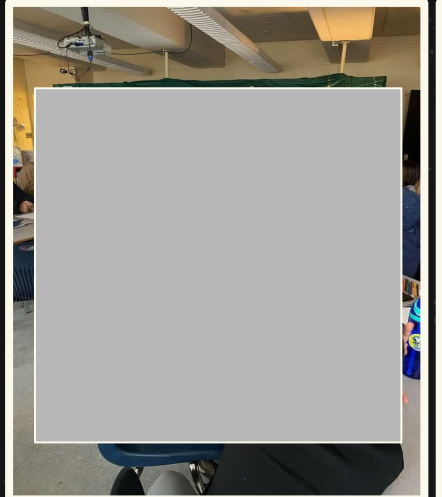
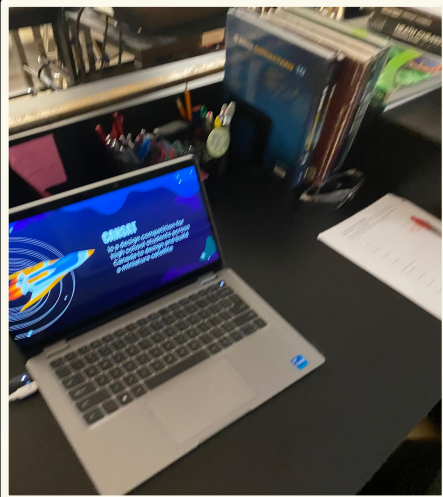
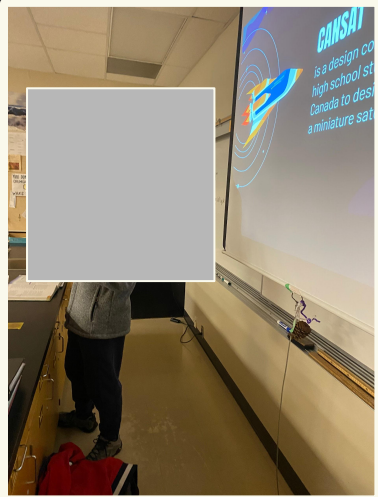

 **TurkeyBurkey**  
@TurkeyBurkeyCanSat 5 subscribers 4 videos  
More about this channel >

HOME VIDEOS SHORTS PLAYLISTS CHANNELS ABOUT

Shorts

 smoothest printer ever  
1.9K views

 Satisfying PCB Scrubbing Sounds ASMR  
84 views

Videos ▶ Play all

 epic hammer sounds  
0:18

 satisfying tape peel  
0:04

# Outreach Details

## Elementary

1-hour workshop on satellites with a design challenge

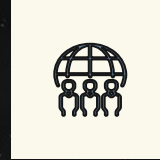

## Public

30-minute discussion on CanSat with Q&A session

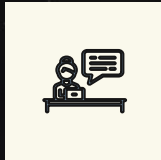

## Online

15-minute presentation on CanSat design process

Coding explanations and engaging videos online

# Adaptability

	<b>Seismometer</b>	<b>Display</b>	<b>Outreach</b>
<b>Challenge</b>	Seismometer program was nonfunctional	Display screen was unreliable & inefficient	Logistical and scheduling challenges
<b>Discovery</b>	During initial process of building seismometer	During GPS testing	During contact with elementary school teacher
<b>Solution</b>	Adapted to new code using different sensors	Transferred data to display on laptop	Communicated with sponsor teacher

# Thanks!

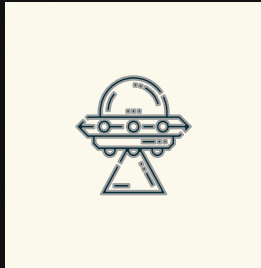

: @turkeyburkeycansat



: @turkeyburkeycansat



: @turkeyburkeycansat



: nuggetbucket54/CanSat

